

ELECTROMAGNETIC STATIONARY-FIELD

TOOTHED CLUTCHES Type SED



ASSEMBLY EXAMPLES

Assembly joining two independent shafts using an elastic coupling

Figure 1

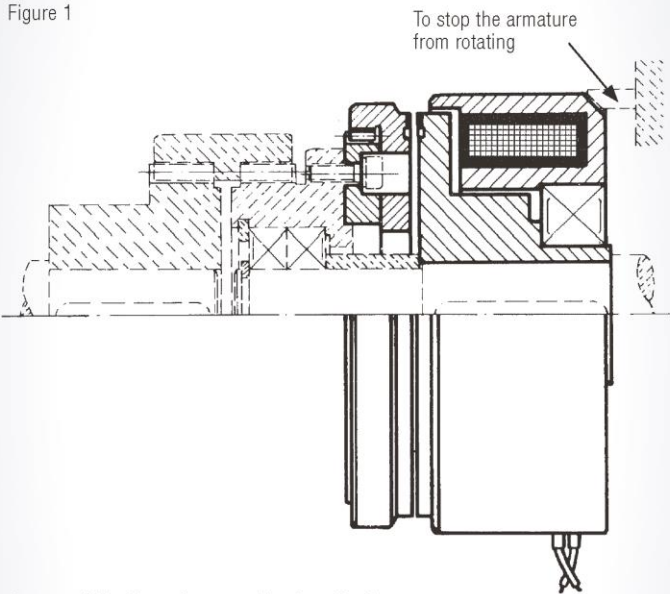

Assembly fitted to a single shaft with sprocket

Figure 2

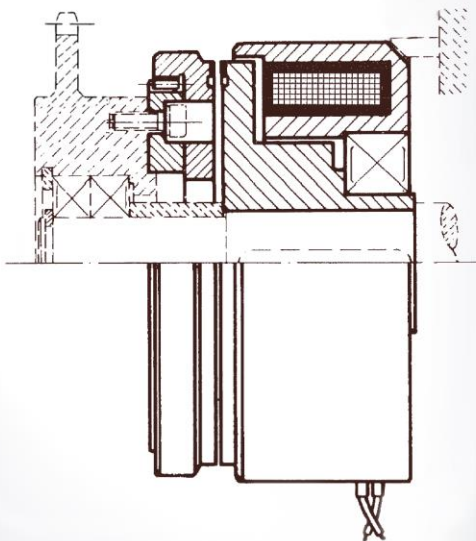

Description

The electromagnetic stationary-field toothed clutches type SED are characterised by their small size with relation to their high capacity to transmit torque and by their self-centred field magnet by bearings.

By their design, these units do not permit slippage and thus should be selected with an adequate safety margin.

Clutch engagement should be carried out while stationary, or at low speeds, depending on the inertia of the systems.

The greater the inertia, the slower the engagement can work in any position, as well as in lubricated environments, such as gearboxes, etc.

Due to their special design, they require no special maintenance.

Applications

Coupling mechanisms in all sorts of machines with high torque that require no slippage, little room, etc. and that can be connected when stationary or moving slowly.

Assembly

They can be fitted to couple two aligned shafts, with an elastic coupling, or to join parallel shafts with sprockets, pulleys, etc. –See assembly examples–.

Connect voltage while stationary or moving at a very slow speed

Supply voltage 24VDC - Other voltages on request

ELECTROMAGNETIC STATIONARY-FIELD TOOTHED CLUTCHES

Type SED

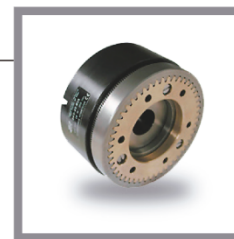

Dimensions

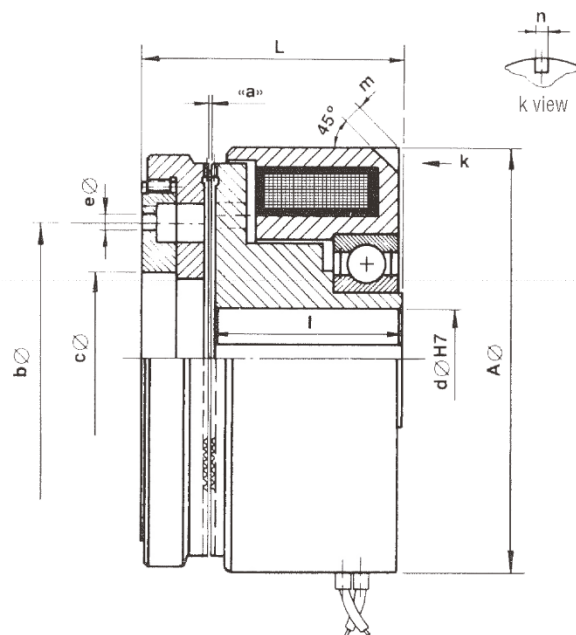

Keway DIN 6885

SIZE		4	10	20	40
Torque	Nm.	40	100	200	400
Max. r.p.m. –once the clutch is engaged–	n	5500	4000	3200	2800
Coil consumption	W	15	20	25	30
Mass	kg	1,4	2,5	4	7,5
Air gap dimension "a" disengaged	mm	0,2	0,2	0,3	0,4
	A	80	100	118	149
	b	50	64	78	100
	c	32	53	60	85
standard	d	15	20	25	30
max.	d	20	25	30	35
	e	6 x Ø4,24	4 x Ø5,25	6 x Ø6,5	6 x Ø6,5
	L	50	54	65	78
	l	35,7	37,5	45	50
	m	4	5	6	6
	n	4	5	6	6

