

SAFETY BRAKE DEVICE TYPE FPC

Instructions valid for sizes 500, 1000, 3500 and 6000

TABLE OF CONTENTS

TABLE OF CONTENTS	Page 1
DESCRIPTION AND OPERATION	Page 2
CHARACTERISTICS	Page 2
DIMENSIONS	Page 3
CHECKING ON RECEPTION	Page 3
IDENTIFICATION	Page 4
ASSEMBLY TO MACHINE	Page 5
STRUCTURE MACHINING MEASURES	
RACK AND PINION ADJUSTMENT TOLERANCES	
MICRO SWITCH CONNECTION	Page 6
PRECAUTIONS WHEN FITTING THE TOP	
UNLOCKING PROCEDURE	Page 7
RECOMMENDATIONS FOR ADEQUATE BRAKE MAINTENANCE	Page 7
TESTING AND CHECKS	
ADJUSTMENT AND TESTING AT EMBRAGATGES I DERIVATS, S.A.	
INITIAL TESTING IN THE APPLICATION	
PERIODIC SERVICES	
ADDITIONAL SERVICES	
USEFUL LIFE OF THE BRAKE	
BRAKE PRESERVATION FOR LONG-TERM MACHINE STORAGE IN THE OPEN AIR	Page 8

Read these instructions carefully before installing your safety brake.

Please contact our technical service with any queries:

Tel. +34 93 714 65 11 – eide@eide.net



Embragues y Frenos Electromagnéticos · Neumáticos
Frenos Mecánicos de Seguridad (Centrífugos y Paracaídas)
Acoplamientos Elásticos · Limitadores de Par · Unidades Especiales

Electromagnetic, pneumatic brakes and clutches
Mechanical safety brakes · Centrifugal brakes
Flexible couplings · Torque limiters · Special units



www.eide.net

DESCRIPTION AND OPERATION

The safety brake device type FPC is a mechanical unit intended to prevent accidental falls in lifting mechanisms powered by rack and pinion.

The system only acts when the speed exceeds a certain, previously adjusted, value.

The brake has sensor elements that act by centrifugal force, locking the brake when a certain speed is exceeded. The interlocking occurs progressively, leaving the machine immobilised once braked.

By operating the machine in the direction contrary to the interlock, the safety brake releases and returns to a position from where it can act again.

These safety brakes incorporate a micro switch which acts in the event of an interlock, which means the signal can be used to generate an alarm and cut the main power from the machine.

The brake must be solidly fixed to the structure of the machine so that its central rotating pinion is perfectly centred and engaged in the rack.

The energy of the system is downloaded on the brake, which is composed of four areas that are loaded until the planned setting torque is reached. Once the movement has been stopped, the machine is immobilised by the static brake torque.

The safety brake is a safety element which must not be damaged by blows or falls. Avoid aggressive mounting methods or treatment that could damage the mechanism and affect its proper functioning.

The brake must be released after any application. See the release procedure on page 7.

Our products are manufactured in accordance with the quality standard UNE EN ISO 9001:2015.

They conform to the UNE-EN 12158-1, UNE-EN 12159 and UNE-EN 1495 standards.
According to certificates no. CM/010/09-1, CM/084/15 and CM/087/17 issued by:



Conforming to Directive 2014/33/EU and harmonised standards EN81-1, EN81-2 and prEN81-7 according to EC examination type no. 08/08/X22/2/000770.

CHARACTERISTICS

SIZE	LOCK SPEED	TORQUE ADJUSTMENT
FPC-500	160 – 400 rpm	100 – 500 Nm
FPC-1000	160 – 400 rpm	350 – 1250 Nm
FPC-3500	150 – 300 rpm	900 – 3800 Nm
FPC-6000	150 – 300 rpm	2000 – 7000 Nm

DIMENSIONS

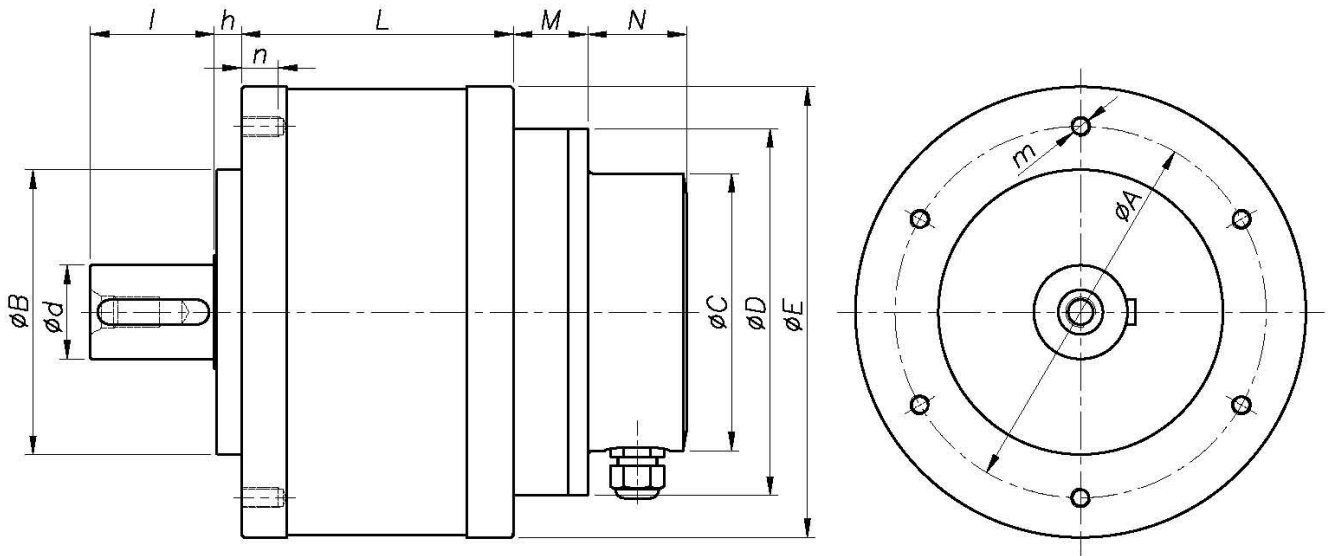

SIZE	$A\phi$	$B\phi$	$C\phi$	$D\phi$	$E\phi$	$d\phi$	$m \times n$	l	h	L	M	N
FPC-500	120	90	112	148	132	28	6 M8x15	40	8	71	38	40
FPC-1000	150	115	112	148	182	38	6 M8x15	50	11	106	30	40
FPC-3500	205	150	112	148	245	50	6 M10x19	60	16	117	36	40
FPC-6000	205	150	112	148	245	60	12 M12x19	80	16	195	36	40

CHECKING ON RECEPTION

1. Make sure that the brake is that appropriate for the machine in all its characteristics, rack location, pinion, total weight and speed.
2. Verify the centring hole. It can enter with a slight gap, but not more than 0.5 mm. Measurements on page 5.
3. Use bolts with a minimum quality of 8.8 according to ISO 898. Tighten the bolts with a torque of 25Nm for M8 screws, 45Nm for M10 and 85Nm for M12 screws. The use of a Loctite type CCXLIII screw fixer or similar is recommended. Use screws in all fixing holes.

IDENTIFICATION

Unpack the unit and check that it has not suffered any damage in handling and transport.

All brakes are marked with a characteristics label with the following information:

Brake:

- FPC brake type
- Brake torque (Nm)
- Revolutions at which the brake locks
- Locking turn direction (front view)
- Date

Application (optional)

- Total maximum weight (kg.)
- Speed (m/min.)

Of the pinion (if fitted)

- Module: (M)
- Number of teeth: (Z)



Of the manufacture

- Manufacturing order
- Reference

As well as another label with the dates of manufacture, servicing and replacement expressed in months and years.

03-2019	Fecha de fabricación Manufacturing date
03-2023	Fecha de revisión Revision date
03-2027	Fecha de sustitución Replacement date



WARNING:

Make sure all these data match your order and the machine for which the service is intended.

Safety brakes for applications with clockwise rotation cannot be used for counter-clockwise applications, or vice versa.

No safety brake can be mounted to a machine other than that described. The brake is adjusted exclusively for each application.

Thanks to its sealed construction, the brake complies with all applicable provisions of the Machinery Directive 2006/42/EC on machine safety.

The brake must not be applied before the machine for which it is intended is declared to be conform with Directive 2006/42/EC.

ASSEMBLY TO MACHINE

STRUCTURE MACHINING MEASURES

FPC-500

FPC-1000

FPC-3500

FPC-6000

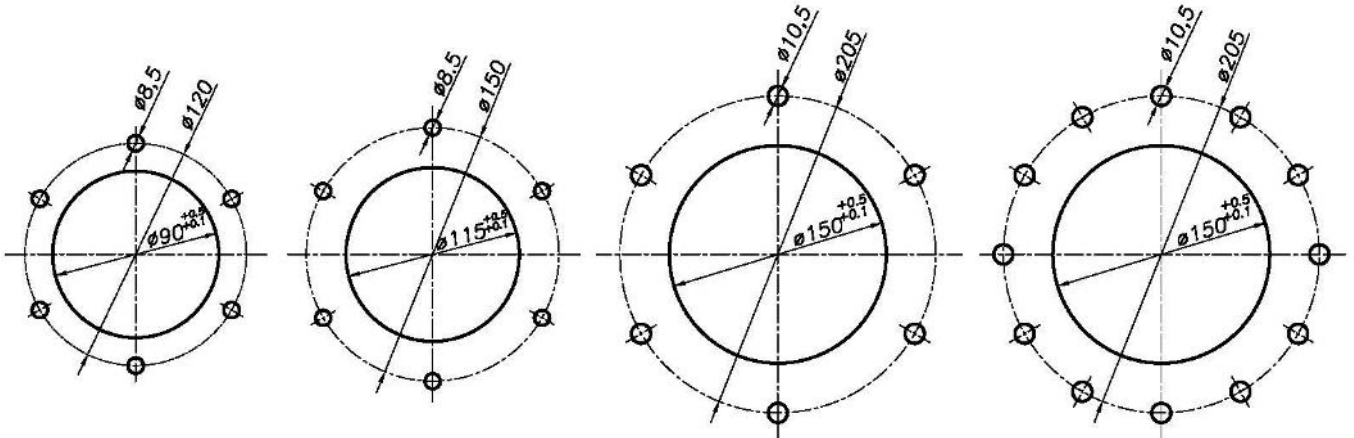

RACK AND PINION ADJUSTMENT TOLERANCES

Ensure the correct axial position between rack and pinion and the radial gap

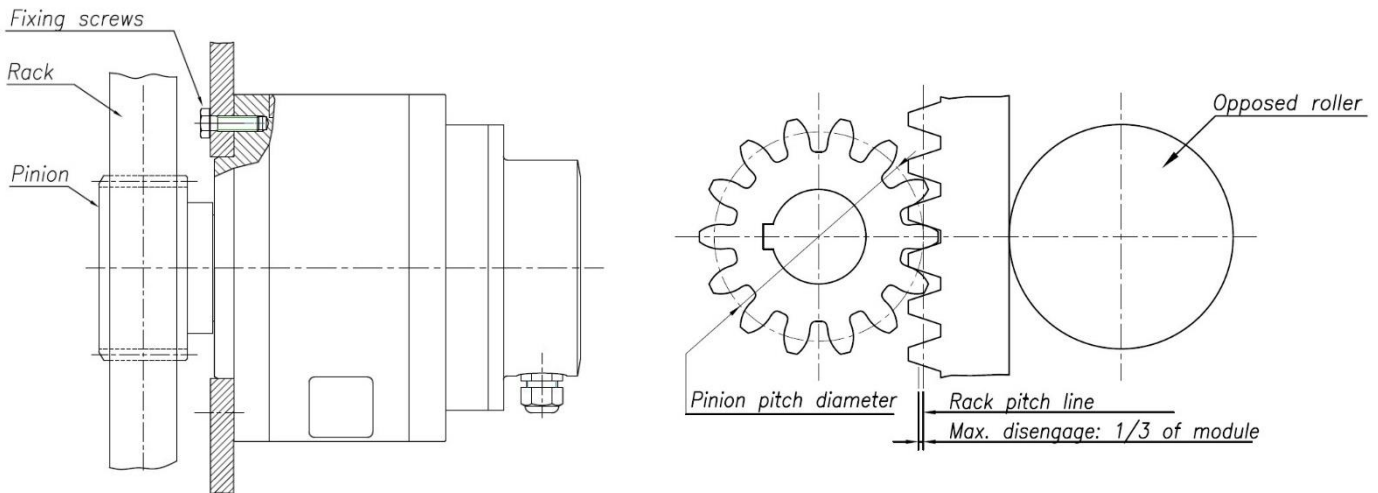

The pinion should cover the entire length of the rack and its disengagement may not be more than 1/3 module at any point.



WARNING:

Safety brakes must be placed below the drive pinions. The gearing of this safety system and the respective counter-roller cannot be used as elements to guide the working platform. The guiding systems must guarantee that, under any load type, upright flexion, or even the breaking of the counter-roller, the distance between the pinion and the rack cannot exceed 1/3 of tooth height.

MICRO SWITCH CONNECTION

The micro switch is protected within the safety brake itself by a cover that ensures a good seal (IP-65), which guarantees correct operation despite being in dusty, rainy or marine conditions.

Access to the micro switch is by removing the back cover held with 6 screws.

Connecting the micro switch according to the diagram.

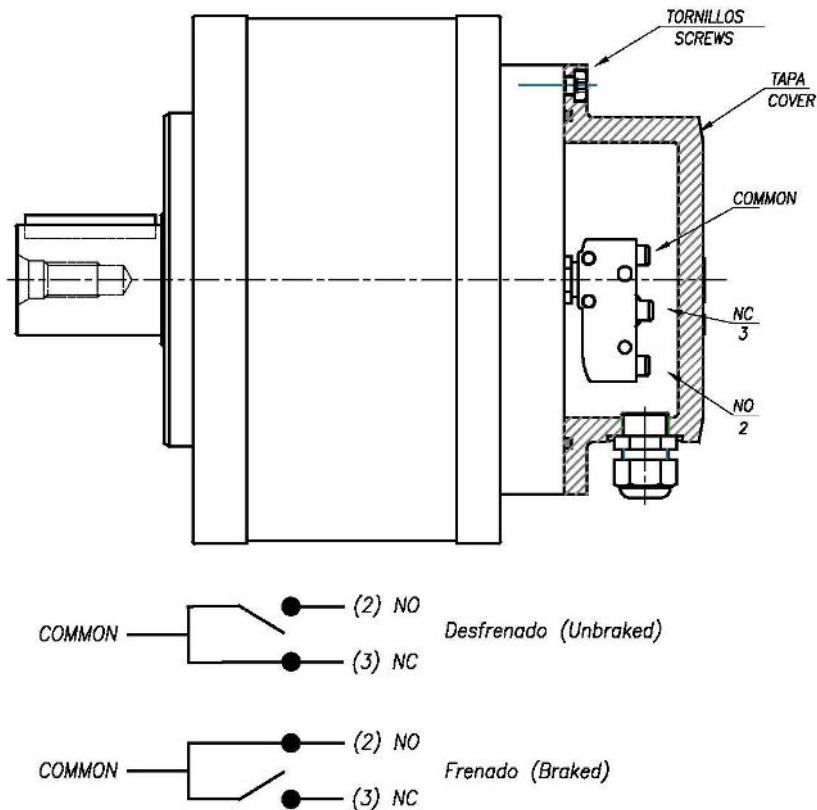

The micro changes state when the brake is locked. The micro recovers its initial position when the brake is released.

PRECAUTIONS WHEN FITTING THE TOP

- Preferably fit the top so that the cables come out of the bottom.
- Make sure the gland around the cable connecting the micro switch is well sealed.
- Make sure the top seal is properly housed.
- Tighten the three M6 screws with a torque of 8 Nm.

UNLOCKING PROCEDURE

The brake locks when it reaches a higher than regulated speed.

The safety brake must be released (reset) after any locking. To release the brake, from where it is, the machine should be moved contrary to the locking movement (about 20 cm is sufficient).



WARNING:

Using the machine with the brake locked produces great wear that reduces the service life of the brake. The energy is dissipated into heat on the brake itself and can even destroy it.

RECOMMENDATIONS FOR ADEQUATE BRAKE MAINTENANCE. TESTING AND CHECKS

ADJUSTMENT AND TESTING AT EMBRAGATGES I DERIVATS, S.A.

The safety brakes are adjusted in accordance with the brake application data provided by the machine manufacturer. All brakes are tested at Embragatges i Derivats, S.A. for their correct operation.

INITIAL TESTING IN THE APPLICATION

During the initial installation of the brake on the machine, it is the customer's responsibility to make the necessary tests to check whether it works properly. We recommend carrying out a first test without load. Carry out tests with part of the load and with the entire load and **always without personnel in it.** Only specifically trained personnel can perform this operation.

In every new machine installation where the brake is mounted, it will be tested by the machine owner as an initial test to verify its operation.

PERIODIC SERVICES

- WEEKLY. To ensure the brake operation, the machine owner, or the user by delegation in their absence, should check the condition of the rack and pinion, ensuring cleaning and greasing.
- EVERY 6 MONTHS. To ensure the brake operation, the machine owner, or the user by delegation in their absence, should test the safety brake every six months (or earlier if the application requires).

This test consists of making a drop test so that the brake comes into operation. Only specifically trained personnel can perform this operation.

- **AFTER 4 YEARS.** After this time, the brake must be sent to Embragatges i Derivats, S.A. for servicing to ensure its operation for 4 more years. If it cannot be sent after four years, the brake must be replaced at the expense of the manufacturer or machine owner.

EMBRAGATGES I DERIVATS, S.A. ACCEPTS NO RESPONSIBILITY for the brake operation if the brake is not sent to Embragatges i Derivats, S.A. for the four-year service.

ADDITIONAL SERVICES

The FPC type safety brakes can perform a large number of actions without damage, but after operation due to true incident of the machine, an authorised technician must imperatively make a full test to check the brake's operation.

USEFUL LIFE OF THE BRAKE

- **AT 8 YEARS.** The brake must be replaced.

EMBRAGATGES I DERIVATS, S.A. ACCEPTS NO RESPONSIBILITY for the brake operation after eight years from its manufacture date.

PRESERVATION OF THE MACHINE IN THE OPEN AIR FOR LONG-TERM STORAGE.

We recommend taking the following precautions when storing machine where the brake is installed outdoors for more than 6 months. The 6-month interval should be reduced to 3 months for places with low temperatures (-5°C or lower) and/or high humidity (80% or higher).

- Remove the safety brake from the machine and place it in a safe place not below 5°C or above 40°C.
- Apply oxidation protector to the shaft and pinion.
- Examine the surface and touch up any paint damage with anti-corrosive epoxy primer.
- Store the brake ensuring that the shaft is horizontal.

The brake must be protected from the rain and not exposed to direct sunlight. Full coverage by plastic or tarpaulins must be avoided, as this will lead to accumulation of moisture due to condensation and cause damage to the brake.

After a long period of inactivity, brake testing is necessary to ensure the operation. Have an initial test made of the machine by specifically trained personnel.



WARNING

Brake disassembly is prohibited. Any manipulation of the brake or of its seal will release the brake manufacturer from any responsibility with regard to its operation.